

M2 mounting hole  
Minimum thread depth  
3mm

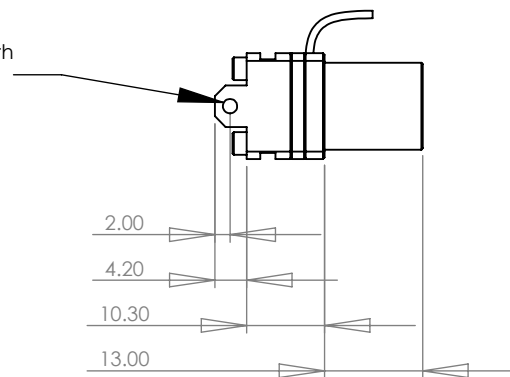
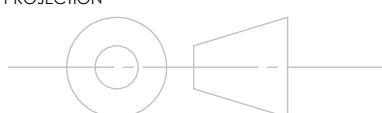

DWG No.	M100 Sub Assembly	DRAWN	I.F.	ISSUE	V2.0
TITLE:	M100 Submersible assembly	<b>TCS Micro Ltd</b>			
PROJECTION		Material	Various	DATE	21/10/2011
		FINISH	Good quality machine finish free from burrs. Anodised where appropriate	SCALE:	1:1
		TOLERANCE	Unless otherwise stated: Dimensions / CAD model +/- 0.05mm		
TEL: +44 (0)1795 539655		EMAIL: info@micropumps.co.uk		SHEET	A4 - 1 OF 1